



INDUSTRIAL AUTOMATION

[Brochure]

["Prima regula a oricarei tehnologii folosite intr-o afacere este ca automatizarea aplicata unei operatiuni eficiente va mari eficienta."]



["The first rule of any technology used in a business is that automation applied to an efficient operation will magnify the efficiency"]

DESPRE NOI

ABOUT US



- **Ne-am construit** compania având în vedere un obiectiv simplu: să ne ajutăm clienții să-și atingă obiectivele de producție. Ne concentrăm pe succesul dvs. și folosim cunoștințele noastre în automatizare pentru a proiecta, construi și programa sisteme de automatizare industriale eficiente și fiabile, care vă vor revoluționa productivitatea.
- **We built** our company with one simple goal in mind: to help our clients achieve their production goals. We are focused on your success, and use our knowledge in automation to design, build and program efficient and reliable industrial automation and control systems that will revolutionize your productivity.
- **Oferim** expertiza noastră în fiecare etapă a ciclului de viață al proiectului dumneavoastră. Ascultăm îndeaproape cerințele și obiectivele dvs, oferindu-va îndrumări pe tot parcursul procesului pentru a ne asigura că sistemele dumneavoastră sunt proiectate corespunzător pentru nevoile dumneavoastră unice.
- **We provide** our expertise at each stage in the lifecycle of your project. We listen closely to your requirements and goals, providing our guidance throughout the process to ensure that your systems are properly designed for your unique needs.

CERTIFICARI

CERTIFICATIONS

- **Vision-Tech** este un ansamblu de activități sistematice desfășurate de întreaga organizație pentru a eficientiza și atinge eficient obiectivele companiei astfel încât să ofere produse și servicii cu un nivel de calitate care satisface clienții, la momentul și prețul potrivit.

- **Vision-Tech** is a set of systematic activities carried out by the entire organization to a efficiency and effectively achieve the company's objectives in order to provide products and services with a level of quality that satisfies customers, at the right time and at the right price.

- **Calitatea** a reprezentat mereu o prioritate pentru organizația noastră. În cele din urmă, succesul companiei noastre se datorează calității produselor și serviciilor noastre.

- **Quality** has always been a priority for our organization. Ultimately, the success of our company is due to the quality of our products and services.



ISO 9001

SERVICII

SERVICES

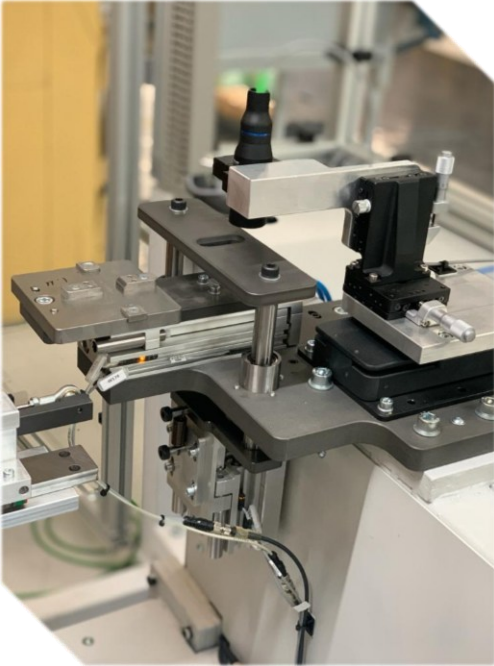

- **Proiectare.**
 - Software CAD, CAM.
 - Desene de ansamblu.
 - Desene de executie si asamblare.
 - Inginerie inversa.
- **3D modelling and design.**
 - 3D modelling CAD, CAM.
 - Engineering assembly drawings.
 - Engineering manufacturing drawings.
 - Reverse engineering.
- **Productie piese/piese de schimb.**
 - Strunjire si frezare CNC.
 - Printare 3D.
 - Tratamente.
- **Manufacturing parts and spare parts.**
 - Custom CNC turning and miling.
 - Custom 3D Printing.
 - Treatments
- **Asamblare mecanica si electrica.**
 - Asamblare electrica echipamente.
 - Asamblare mecanica echipamente.
 - Instalare si punere in functiune echipament la client.
- **Mechanical and electrical assembly.**
 - Panel building.
 - Custom assemblies.
 - On-site system installation.

SERVICII SERVICES



Oferim consultanta completa nu doar pentru proiectarea de solutii noi de automatizare ci si pentru sistemele dumneavoastra actuale care pot fi imbunatatite.

We offer complete consultancy not only for the design of new automation solutions but also for your current systems that can be improved.

- **Scheme electrice si proiectare.**
 - Proiectare 2D and 3D pentru asamblarea tablourilor electrice.
 - Scheme electrice.
 - Scheme pneumatice.
- **Electrical diagram and design.**
 - Design 2D and 3D for panel building.
 - Circuit diagrams and schematics drawings.
 - Fluid diagrams and schematics drawings.
- **Programare.**
 - DCS, PLC, PAC, HMI branduri de top.
 - Integrare Scada si MES.
 - Roboti,scara,delta si coboti branduri de top.
 - Dezvoltare IOT.
- **Programing.**
 - DCS, PLC, PAC, HMI top brands.
 - Scada and MES integration.
 - Robots, scara, delta and cobots top brands.
 - IoT services development.

Ø GAMA LARGA DE APLICATII

A WIDE RANGE OF APPLICATIONS

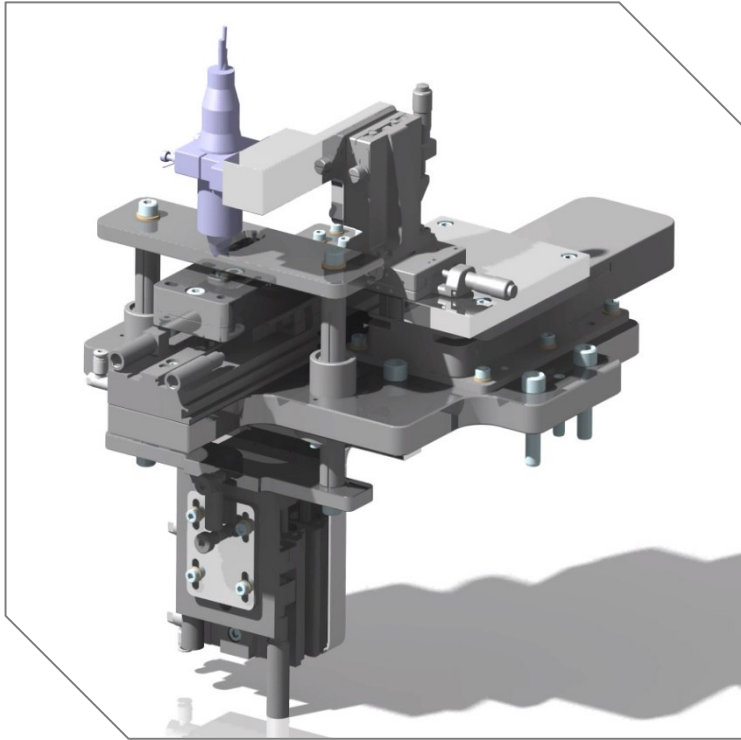

- **Manipulare**

- Pick and place.
- Asamblare.
- Sortare.
- Ambalare.
- Alimentare.

- **Manipulation**

- Pick and place
- Assembly
- Sorting
- Packaging.
- Feeding

- **Sudura**

- Laser.
- Ultrasonic.
- Sudura.

- **Welding**

- Laser
- Ultrasonic
- Welding

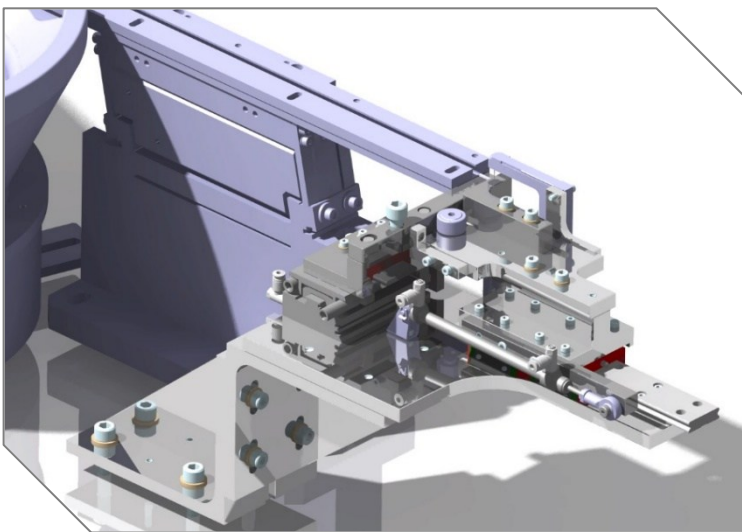

◉ GAMA LARGA DE APLICATII

▲ A WIDE RANGE OF APPLICATIONS

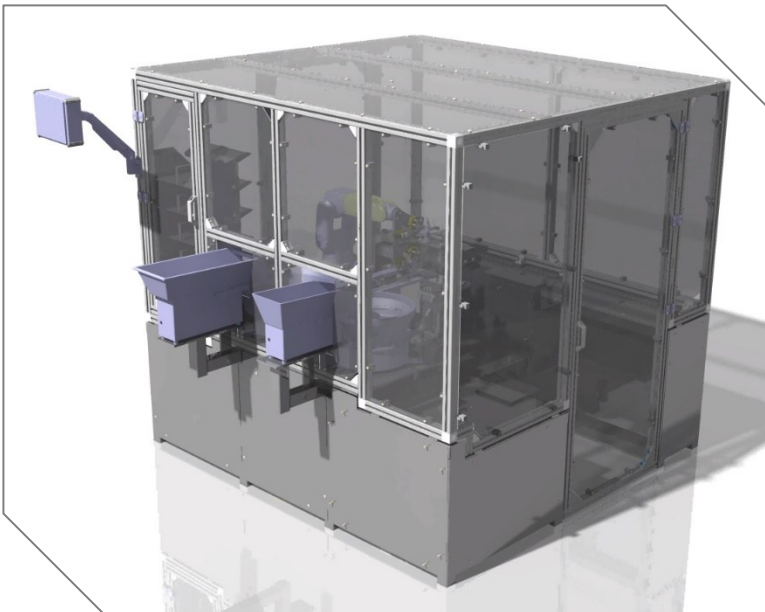
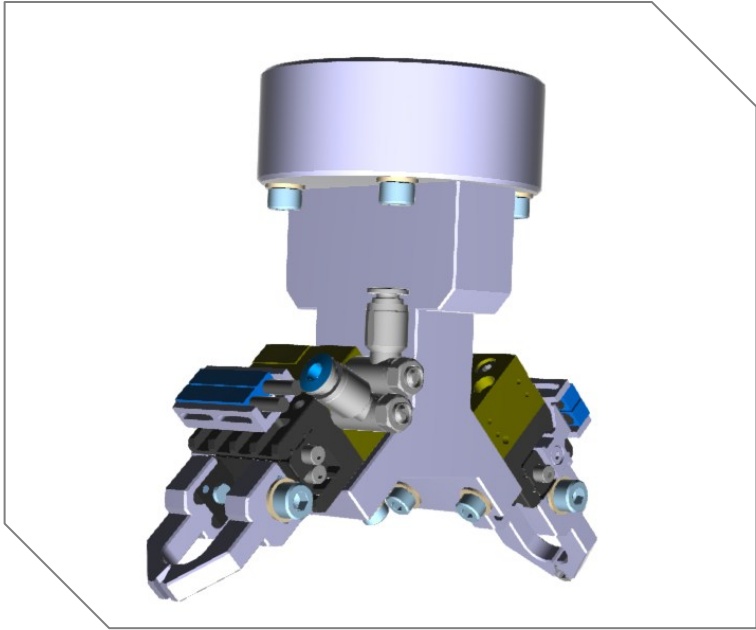

- **Masurare, presare, marcare si testare**

- Presare cu preluare date forte si pozitii.
- Testare de tensiune inalta (HV-Test)
- Echipamente finale (EOL).
- Inspectii vision (AOI).
- Masurare si stocare date.
- Teste de continuitate.
- Testare etanseitate.
- Marcare laser.
- Marcare cu vopsea.
- Marcare cu cerneala.

- **Measuring, pressing, marking and testing**

- Force cell pressing with data acquisitions.
- High voltage test (HV-Test).
- End of line (EOL).
- Vision inspections (AOI).
- Measuring and data collect.
- Continuity tests.
- Leak tests.
- Laser marking.
- Paint marking.
- Inkjet marking.

GAMA LARGA DE APLICATII

A WIDE RANGE OF APPLICATIONS



- **Prelucrare**

- Stantare.
- Nituire.
- Insurubare cu preluare date forta si unghi.
- Unitate de dispensie.
- Unitate de gresare.
- Aplicare compozitii de mixare.
- Sertizare.
- Embosare.

- **Processing**

- Stamping.
- Riveting
- Screwing with collecting data torque and angle.
- Dispensing units.
- Greasing units.
- Application of mixing composition units.
- Crimping.
- Embossing.

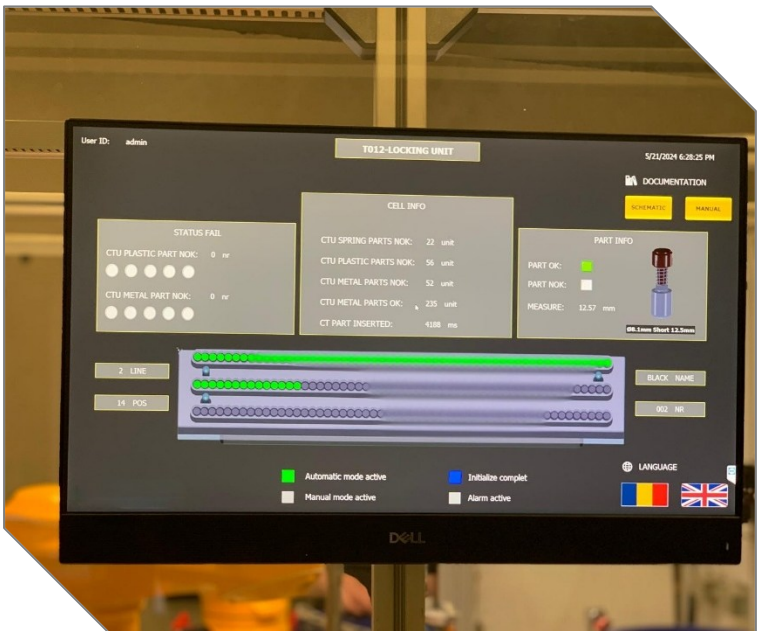

CONCEPTE INTEGRATE

INTEGRATED COCEPTS



- Celule de asamblare, testare si proces.
- Mese rotative cu diferite aplicatii (Celule de presare, insurubare, masurare, inspectii vision).
- Sisteme de indexare lineare controlate cu cama.
- Sisteme de asamblare interconectate intre ele pe procese.

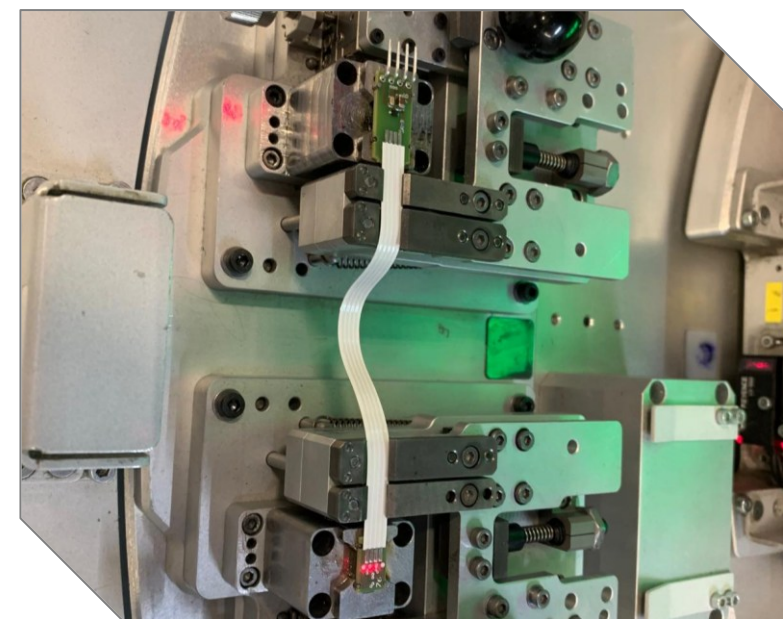

- Assembly cells, test and process.
- Rotating tables with different applications (force press, screwing, measuring, vision inspections)
- Linear systems controlled by cam.
- Interlinked assembly systems.
- Robot cells and collaborative robot stations.
- Feeding cells with vision coordinate position to robots.

SUPPORT SI MENTENTA

SUPPORT AND MAINTENANCE

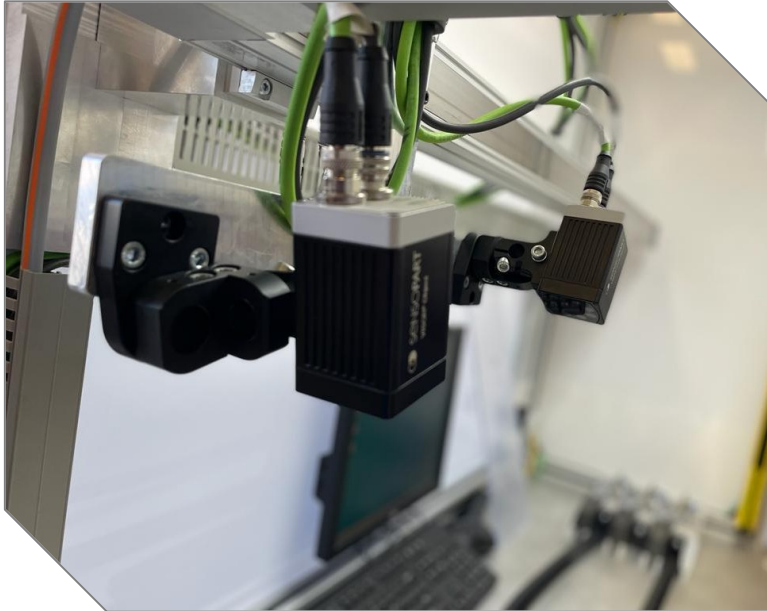

- Daca este necesar va putem instrui personalul pentru operare si intretinere.
- Ne vom sprijini clientii pentru implementare si intretinere.
- Oferim si contracte de intretinere pentru echipamentele dumneavoastra.



- If necessary, we can train your staff for operation and maintenance.
- We will support our clients for implementation and maintenance.
- We also offer maintenance contracts for your equipment.

CONTACTE

CONTACTS



OFFICE:



Nume: Gherghe Diana



Telefon: +40 744 768 780



Email: office@vision-tech.ro

AUTOMATION:



Nume: Hantiu Bogdan



Telefon: +40 722 613 505



Email: engineering@vision-tech.ro